

Power Input Line Risks and Protection

AC power line disturbances are the cause of many equipment failures. The damage can be as elusive as occasional data loss or as dramatic as the destruction of a power supply, LED Lightings, Industrial system and consumer equipment such as ovens or refrigerators and television sets.

Power line disturbances go by many names—transients, surges, spikes, glitches, etc. But regardless of the specific name, an understanding of their characteristics and the operation of the various protection components available is necessary to design an effective protection circuit.

There are some popular protection components for these power input lines. The most common over voltage protection components are MOVs (Metal Oxide Varistor), high power TVS (Transient Voltage Suppression) Diodes and GDTs (Gas Discharge Tube). In this article, we are going to discuss a new and innovative method of using a silicon crowbar component known as, the SIDACtor® Protection Thyristor component, for the main over voltage protection solution for AC power lines.

Surge Protection

Surge protection components can be divided into two basic types: Crowbar type devices such as GDTs and protection thyristor type SIDACtor® components and clamp type components such as TVS diodes, MOVs etc.

The clamp type components have faster response time but are limited in their current handling ability because the transient energy must be dissipated by the clamping component. Also, the voltage drop across a clamp type component increases as a function of the conducted current passing through it. Thus a higher clamping voltage threshold component will have a lower peak current capability. (the power rating remains the same for all components in a particular series but since power is the product of the voltage and current, an increasing voltage demands a decrease of current).

A crowbar type component can handle much higher surge current because during their on-state condition, the voltage across the component is extremely low. These crowbarring components act as a “near short

circuit value” path shunting the transient energy away from the protected equipment. And this, low on-state voltage will further reduce any electrical over stress to the protected circuit.

SIDACtor® Component in AC Power Line Protection

Questions may arise due to the nature of the SIDACtor® component being a crowbar protection and its compatibility with an AC power source. This article, will review the design parameters for selecting a SIDACtor® component for AC power line protection. Please note that this discussion of the SIDACtor® component use is confined to AC power line only; it is not compatible for high current DC supply ports. The SIDACtor® component will reset on an AC port at the zero-crossing every half-cycle for an AC signal. However, for high current DC power lines, the SIDACtor® component will not reset if the short circuit current available is higher than its holding current parameter. Of course, if you series SIDACtor® Component with TVS or MOV, it can be used on DC power line too. TVS or MOV Vbr should be equal or higher than DC max voltage

Littelfuse Pxxx0FNL and Pxxx0ME Series SIDACtor® Component

The Littelfuse Pxxx0FNL and Pxxx0ME Series high energy SIDACtor® component has a crowbarring characteristic, which offers low on-state voltage values that are much lower than the arc voltage of the traditional GDT and it offers a much lower voltage threshold than the clamping voltage of an MOV. Compared to clamping silicon TVS diodes, the Pxxx0FNL and Pxxx0ME SIDACtor® component can handle a much higher surge current since its on-state-voltage is so low. It also provides a much lower over-shoot characteristic for high dv/dt or high di/dt events as compared to the GDT, MOVs or TVS components.

The Pxxx0FNL and Pxxx0ME series have component working voltage (V_{DRM}) (also known as off-state voltage) ranging from 58v to 450v. Referring to the I_{PP} surge current and I_{TSM} table, the Pxxx0ME provides 5000A 8/20 I_{PP} (peak pulse current rating) and a minimum 400A I_{TSM} for 50/60Hz AC single cycle sinusoidal wave surge event and Pxxx0FNL provides 3000A 8/20 I_{PP} and a minimum 300A I_{TSM} for 50/60Hz AC single cycle sinusoidal wave surge event.

Product Series of Pxxx0ME Series in TO-218

Part Number	Marking	V_{DRM} @ $I_{DRM}=5\mu A$	V_s @ 100V/us
		V_{min}	V_{max}
P1500MEL	P1500ME	140	180
P1900MEL	P1900ME	155	220
P2300MEL	P2300ME	180	260
P3800MEL	P3800ME	350	430
P4800MEL	P4800ME	450	600

Product Series of Pxxx0FNL Series in TO-262M

Part Number	Marking	V_{DRM} @ $I_{DRM}=5\mu A$	V_s @ 100V/us
		V_{min}	V_{max}
P0640FNL	P0640FN	58	77
P0720FNL	P0720FN	65	88
P0900FNL	P0900FN	75	98
P1100FNL	P1100FN	90	130
P1300FNL	P1300FN	120	160
P1500FNL	P1500FN	140	180
P1900FNL	P1900FN	155	220
P2300FNL	P2300FN	180	260
P2600FNL	P2600FN	220	300
P3100FNL	P3100FN	275	350
P3500FNL	P3500FN	320	400
P3800FNL	P3800FN	350	430

Surge I_{PP} and I_{TSM}

I_{PP}	I_{TSM}
$8/20^1 1.2 \times 50^2$	50/60 Hz
A_{min}	A_{min}
5000 ³	400

Surge I_{PP} and I_{TSM}

I_{PP}	I_{TSM}
$8/20^1 1.2 \times 50^2$	50/60 Hz
A_{min}	A_{min}
3000	300

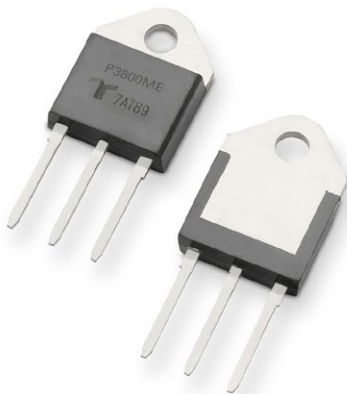
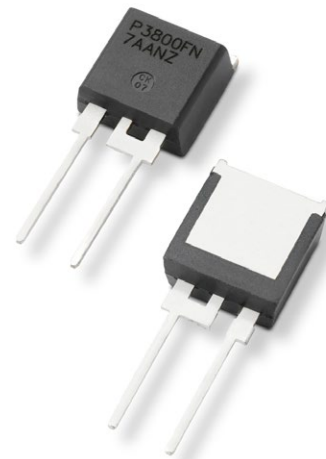
Pxxx0ME Series in TO-218

Pxxx0FNL Series in TO-262M

Notes:

1. Current waveform is μs
2. Voltage waveform is μs
3. P1500MEL to P2300MEL have surge rating of 5kA @ 8/20. For surge rating of P3800MEL, it is a minimum 4kA and typical 5kA@8/20 μs .

Notes:

1. Current waveform is μs
2. Voltage waveform is μs

Littelfuse Pxxx0FNL and Pxxx0ME Series SIDACTor[®] Components

The Pxxx0FNL and Pxxx0ME Series are improved solutions over the conventional GDT. They provide:

- Low on-state voltage condition thus low thermal accumulation during long term events
- Lower overshoot during high dv/dt events
- No wear-out mechanism
- Stand-off values choices that are closer to some country AC power line values without sacrificing over-shoot characteristics (lower voltage GDTs use a different gas/higher gas pressure for lower voltage version, thus resulting in slower turn on characteristics and higher overshoots)

Figure 1b-P3800MEL Crowbar Solution with Series Over Current Protection

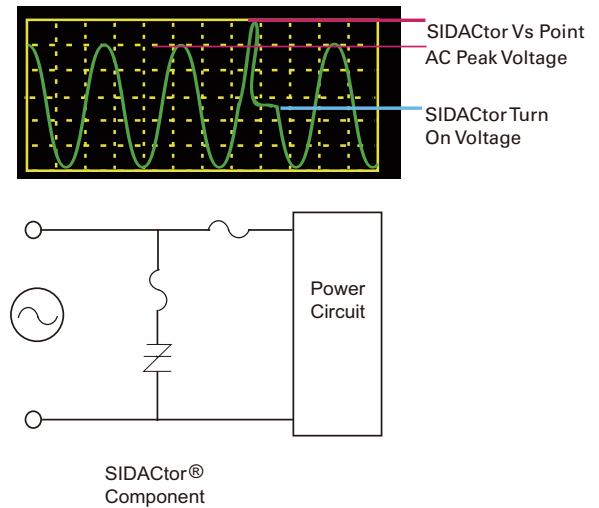
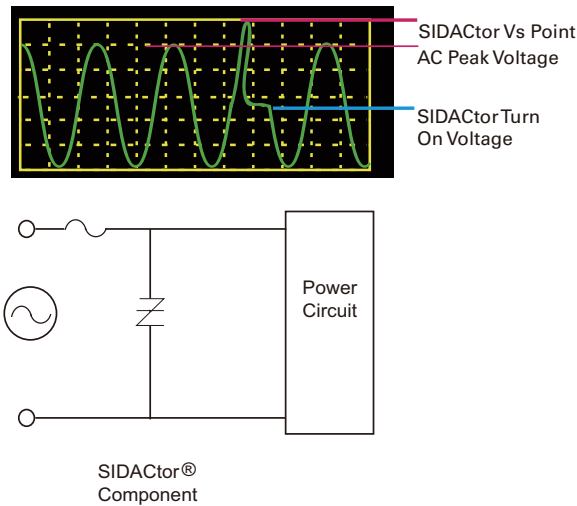

Figure 1a-P3800MEL Crowbar Solution



Littelfuse Pxxx0ME Series SIDACTor[®] Component

Figure 1a and Figure 1b shows a SIDACTor[®] component P3800MEL used with a power line fuse and then with a series overcurrent fuse protector. In normal operation condition, the SIDACTor[®] component and series fuse does not react and work transparently to the power line. When there is an AC voltage or a surge induced voltage exceeding the V_{DRM} of the P3800MEL component, it starts to switch into a low resistance on-state condition. The power line fuse is to protect the SIDACTor[®] component with the current I_{TSM} value that is not exceeded during repetitive sinusoidal follow on AC power events.

This combination would then offer a coordinated overcurrent and overvoltage protection solution for this power port. Figure 1b gives the designer an option for enhanced over current protection dedicated for the SIDACTor. This added series fuse with the SIDACTor® component provides protection to the SIDACTor® component itself from overload or overstress situation. The major difference of this solution requires the power line fuse be placed after the SIDACTor + series fuse combination. The SIDACTor + series fuse provides surge protection for the power fuse and the the line impedance, load, and/or power circuit while the power fuse provides protection to the AC line current and the power circuits. This is especially important if the power circuit requires a sensitive overcurrent protection while this fuse would not be exposed to high surge events. Note that the above protection topologies are some examples. The actual protection scheme will require testing and verification in the actual environments.

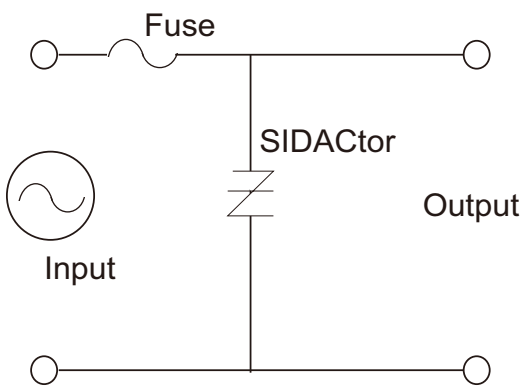
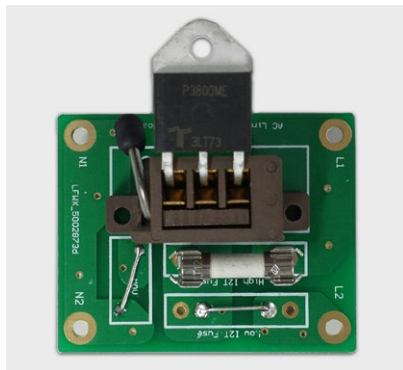

*Note: For the demo board, there are different fuse topology options, as well as SIDACTor® component options. Please refer to demo board application instructions.

Figure 2 shows the SIDACTor® component response to a 3kA 8/20 surge (without a connection to an AC source). The orange line shows the surge waveform of the 3kA @8/20 and the blue line shows the SIDACTor® component response curve. This P3800MEL has an initial peak value of 272V before it crowbars and limits the voltage to <30V.

Figure 3, when the SIDACTor® component responds to a 3kA surge on an AC voltage line, there is a large follow on AC current (278A) applied to the SIDACTor® component. This half cycle high AC current does not harm the SIDACTor® component since the P3800MEL I_{TSM} rating is min 400A (50/60 Hz one cycle AC current rating), which can safely handle. This limiting action is a function of the line impedance, load, and/or the power source current rating.

Figure 2. 3kA 8/20 with P3800MEL(no 240v AC coupling)

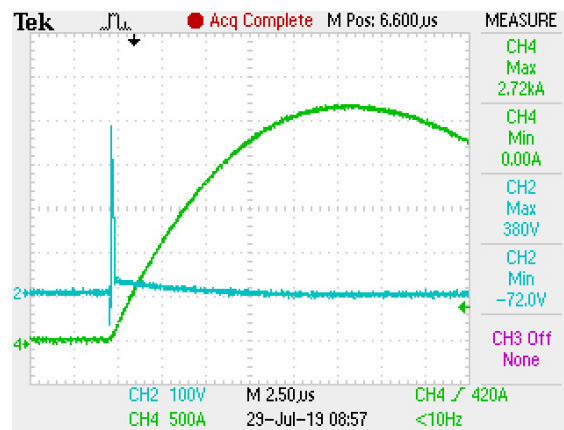
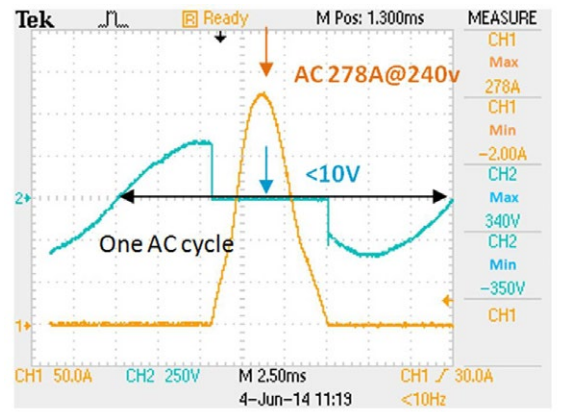

Figure 3. AC current follow on after P3800MEL triggered (with 240V AC coupling)



Using SIDACTor® Component with Other MOV Clamping Devices

The Littelfuse Pxxx0FN and Pxxx0ME series can also be connected in series with an MOV to create low clamp protection for circuits damaged by higher clamping voltages.

The turn-on threshold of the MOV and the SIDACTor® component combination must be higher than the steady-state ac line voltages but once this combination activates, the use of the crowbarring component provides a lower overall clamping voltage than what the MOV can provide by itself.

Figure 4. P2300MEL+V20E130P Low Clamp Solution

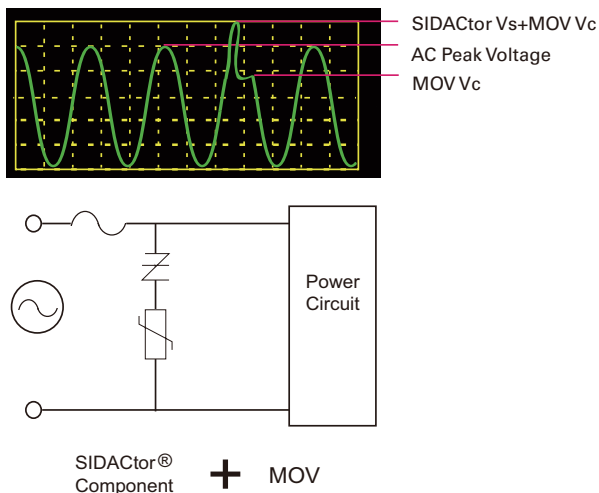
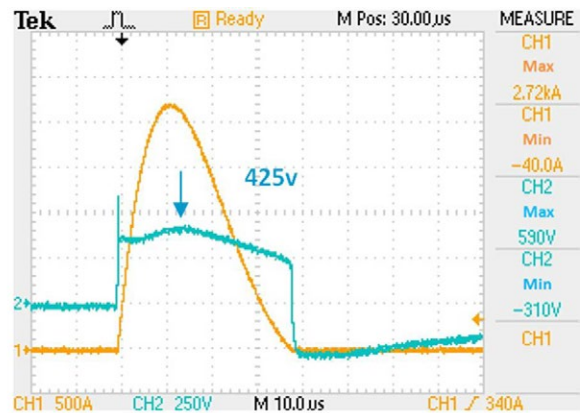

Figure 4 shows a lower working voltage SIDACTor® component P2300MEL (DC 180V) connected in-series with a Littelfuse MOV V20E130P (AC 130V) preceded by a fuse. This complete circuit provides both overcurrent and overvoltage protection for the AC line.

Figure 5 shows that the SIDACTor® component + MOV combination during a 3kA 8/20 surge event and the resulting maximum clamping voltage of 425V, which is higher than the SIDACTor® component alone with a low on-state voltage < 30v. The higher clamping voltage is due to the V20E130P MOV clamping voltage adding together with P2300MEL SIDACTor® component on state voltage, which makes the resultant clamping voltage >30V as found in the previous example. However, if we use the MOV alone, for this 240v AC line, the required MOV would be the V20E275P, and the clamping voltage will go up to more

than 900V, which may harm the following electronics. The differences of the clamping voltage between the SIDACTor® component alone, the combination of the SIDACTor® component + MOV component and the MOV component only solution demonstrates three vastly different protection solution results.

Figure 5. 3kA 8/20 with P2300MEL+V20E130P (no 240v AC coupling)



In Figure 6, after the SIDACTor® component + MOV combination is triggered with the 3kA 8/20 surge, the AC follow on current is measured at 43.2A. The MOV impedance lowers the AC follow on current thus protecting the SIDACTor® component. On the other hand, the SIDACTor + MOV combination can also provide a lower leakage current than that of of a stand-alone MOV solution, thus enhancing the off-state protection to a green status mode (ultra-low leakage current). The addition of the SIDACTor® component provides this low leakage feature. For some sensitive design or regulatory compliance purposes, a current interrupting device (a fuse component) should be added in the line to provide compliance to safety listing requirements.

Figure 6. AC current follow on after P2300MEL+V20E130P triggered in 3kA surge (with 240V AC coupling)

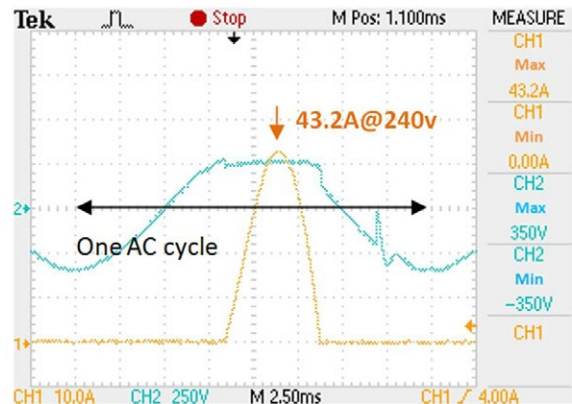

Low clamp protection typical application

Figure 7a: EV/HEV DC charger surge protection for 3 phase AC power line

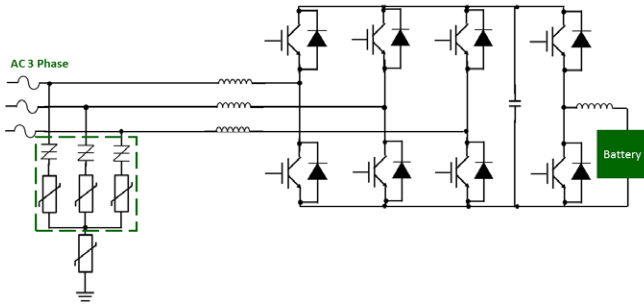
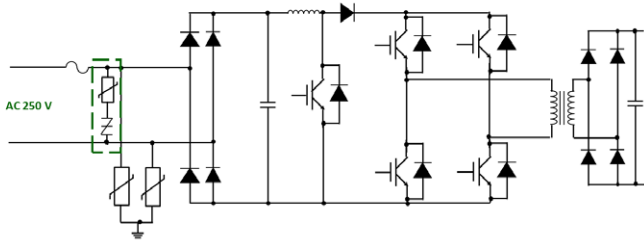
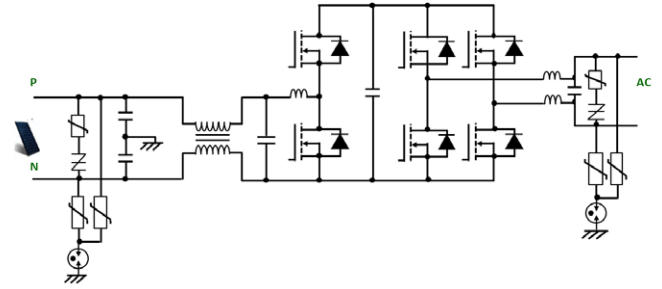

Figure 7b: Inverter surge protection for AC power line



In Figure 7a and 7b, the SIDACTor[®] component + MOV component combination provides an over-voltage protection solution to the input line side of the Inverter driving circuitry. It is intended to allow AC voltage to go into the power switch (like IGBTs / IGBT module / MOSFET) operationally while clamping/adsorbing those unwanted transient noises and disturbances. It can be designed in single-phase or three-phases modes by using 1 or 3 SIDACTor + MOV components respectively. These protection topologies are widely used in EV electric vehicles and HEV Hybrid electric vehicles applications.

Figure 8: PV Photo Voltaic converter protection



As shown in figure 8, the SIDACTor[®] component + MOV is connected differentially (L-N) in the PV cell output to protect against unwanted transients. The current generated from solar cell panels are being regulated by the high voltage switching MOSFETs to the required AC current. The actual SIDACTor[®] component and MOV combination depends on the surge and protection requirement of the PV converter design.

Calculation of The Fuse Rating Protecting The Surge and AC Follow on Current

We need to have a fuse with an interrupt rating greater than the sum of the 3 kA 8/20 surge event and the AC follow on current but lower than the I_{TSM} rating of the SIDACTor® component. This prevents the fuse from causing nuisance openings but opens appropriately to protect the SIDACTor® component. The fuse interrupting value can be best estimated by its I^2t value.

Here we provide an example of how to calculate a total I^2t value for the proper fuse selection during 3kA 8/20 event for the combination MOV+SIDACTor® component circuit.

For Surge: A 3kA 8/20 surge current I^2t is approximately $1/2 * I_{peak} * I_{peak} * t = 1/2 * 3000 * 3000 * 20 * 10^{-6} = 90A^2s$.

For AC: A half cycle AC follow on current I^2t will be $1/2 * I_{peak} * I_{peak} * t = 1/2 * 43 * 43 * 0.01 = 9.245A^2s$.

Total I^2t will be $90+9.245=99.245 A^2s$.

Figure 9. Fuse I^2t Derating Curve

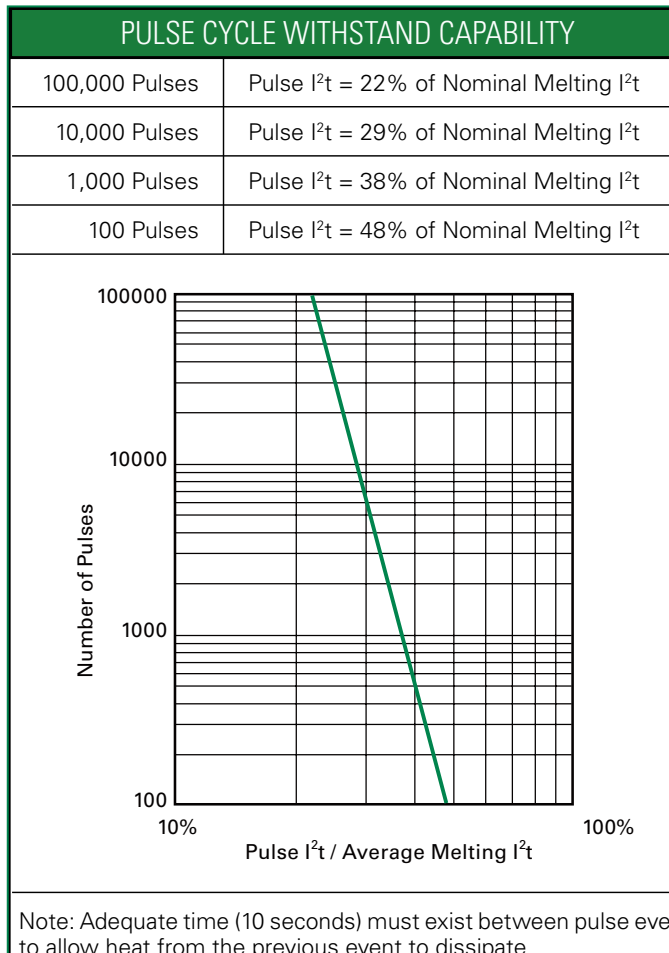

Note that we need to consider fuse de-rating for the expected application ambient temperature conditions and the expected number of pulses. For example, if a fuse needs to take 100,000 pulses, a factor 0.22 (please refer to the Fuse derating curve as Figure 9 showed) should be considered. Note that for surge protection applications, typically, dozens of pulses are considered, hence 0.48 derating factor is sufficient.

As mentioned above, the fuse I^2t needs to be greater than $99.245/0.22=451A^2s$. The half cycle AC SIDACTor® component I^2t value is $1/2 * 400 * 400 * 0.01 = 800 A^2s$. (400A is max I_{TSM} of P3800MEL). It is obvious that the derated I^2t (451 A^2s) is smaller than half cycle SIDACTor® component I^2t (800 A^2s) insuring that the fuse will open BEFORE the I_{TSM} SIDACTor® component rating is exceeded.

For the MOV, normally we calculate its follow on AC current energy to see if the MOV rating is sufficient. In this event, the total current energy through MOV V20E130P is 3kA 8/20 plus the 43A half cycle AC current. So the total energy is $0.71 * 250 * 3000 * 20 * 10^{-6} + 0.71 * 250 * 43 * 0.007 = 10.65 + 53.43 = 64.08J$. This value is less than V20E130P 100J datasheet specification.

Thus, the selected fuse will have an I^2t rating larger than the 3kA 8/20 surge current and AC follow on current energy thus insuring it does not result in a nuisance opening when the OVP solution is functioning as designed.

The fuse with an AC 250V rating and with an I^2t value of 451 is an excellent choice for protecting the SIDACTor® component + MOV component while maintaining the normal operation but providing protection for the SIDACTor® component +MOV component.

Here we list several Littelfuse fuse types which meet above 451 A²S requirement.

	IEC		UL	
	Fast-Acting	Time-Lag	Fast-Acting	Time-Lag
5x20	216016 (462.4A ² S)	215012 (515.5A ² S)		
6.3x32			314020/324020 (631A ² S)	325020/326020 (5575A ² S)

Table1. Fuse Type and Minimum Current Rating for AC Protection Circuit (SIDACTor® Component)

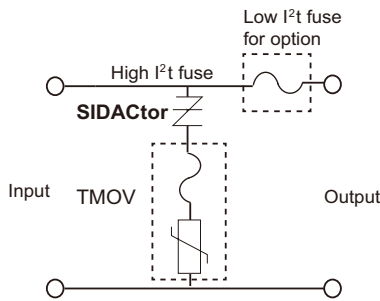

Littelfuse also offers TMOV products which has an integrated thermal protection fuse to shorten the circuit design cycle time

Figure 10. SIDACTor® Component for CATV Amplifier

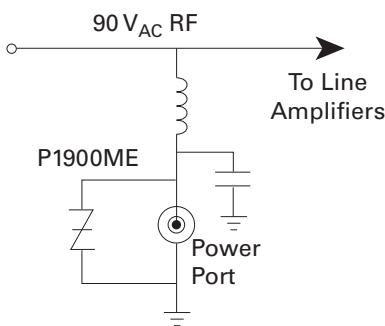

Here is a typical surge protection solution for a CATV 90 Volt sine wave powering scheme:

In Figure 10, The P1900MEL is used because the peak off-state ($V_{DRM}=155v$) voltage is well above the peak, voltage of the CATV power supply ($90 \times 1.414=127v$). Please note the required compensation inductor circuit that prevents the off-state SIDACTor® component capacitance from interfering with the CATV RF signal. This series inductor circuit has important design requirements that should be mentioned here.

Note that a compensation inductor may be required to meet insertion and reflection loss requirements for CATV networks. If so, the inductor should be designed to saturate quickly and withstand surges up to 200 V and 1000 A. An inductor with a core permeability of approximately 900 Wb/A·m and wound with 24-gauge wire to an inductance of 20 μ H to 30 μ H is an example of a suitable starting point, but the actual value depends on the design and must be verified through laboratory testing.

AC	SIDACTor® Component	I _{pp} (8/20)
120	P2300MEL	Min 5kA
240	P3800MEL	Min 4kA

Conclusion:

The Pxxx0ME SIDACtor® component is ideal for AC power line protection. It features a low on-state crowbarring threshold, fast turn-on characteristic, low overshoot, high surge current, precise working voltage values and will not wear out due to repetitive activations within their surge rating. With the suitable fuses / over current element prior to the SIDACtor® component, it forms an excellent protection solution for AC power lines. Again, note that this is only for short term surges on AC power lines and not for high current DC power lines UNLESS the DC is current limited to a level less than the SIDACtor® component holding current parameter OR the DC supply recognizes a short circuit load condition and automatically shuts down.

GDT/SIDACtor® Component/MOV/TVS Comparison

Type	GDT	SIDACtor® Component	MOV	TVS
Protected Mode	Crowbar	Crowbar	Clamping	Clamping
Working Principle	Gas ionization conductive	Controllable silicon architecture	Zinc oxide grain structure	Clamping diode structure (Avalanche)
Response Time	Larger than 1µs	Lower than 1ns	ns level	ns level
Maximum Peak Current	20kA	5kA	70kA	15kA
Lifetime	Low (need to replace regularly)	Long	Low	Long
Residual Voltage	Higher	Low	High	Low
Advantage	large current flow, high insulation resistance, small leakage current, small parasitic capacitance	Strong surge absorption ability, accurate conduction, fast response, low leakage current, high reliability, no wearout mechanism	Low price, large current flow, fast response time	Low clamping voltage, accurate conduction, fast response, high reliability
Disadvantage	Longer response time, slow reaction, high residual pressure, low breakdown voltage precision, easy to age	Low peak current flow	Larger leakage current, higher clamping voltage, higher parasitic, capacitance, easy to age	Higher parasitic capacitance, lower peak current flow

For more information about Littelfuse Semiconductor SIDACTor® component, use the following links or find below items on Littelfuse website.

SIDACTor® Protection Thyristor 5kA Series in TO218

http://www.littelfuse.com/~media/electronics/datasheets/sidactors/littelfuse_sidactor_5ka_to_218_datasheet.pdf.pdf

SIDACTor® Protection Thyristor 3kA Series in TO262M on Littelfuse website

https://www.littelfuse.com/~media/electronics/datasheets/sidactors/littelfuse_sidactor_pxxx0fnl_3ka_datasheet.pdf.pdf

Please refer to P2300SDL/3500SDL for a lower I_{TSM} (min 50Amp) rating in the smaller form factor DO-214AC package.

Visit <http://www.littelfuse.com> for more technical application articles and reference designs serving a wide range of applications.

Littelfuse Technical Support Team

Walt Tian (Asia technical support); wtian@littelfuse.com

Andy Xu (North America technical support); axu@littelfuse.com

Teddy To (Technical Marketing Manager); tto@littelfuse.com