

AB BULLETIN 1406 TO MPS MOTOR PROTECTION SYSTEM RETROFIT

The MPS Motor Protection System is an excellent choice as a replacement for the AB Bulletin 1406 Motor Protector due to similarities in modular design and terminal layout. While the MPS can be programmed to simulate the AB-1406, it can also add protective features, control, metering, data logging, and communications.

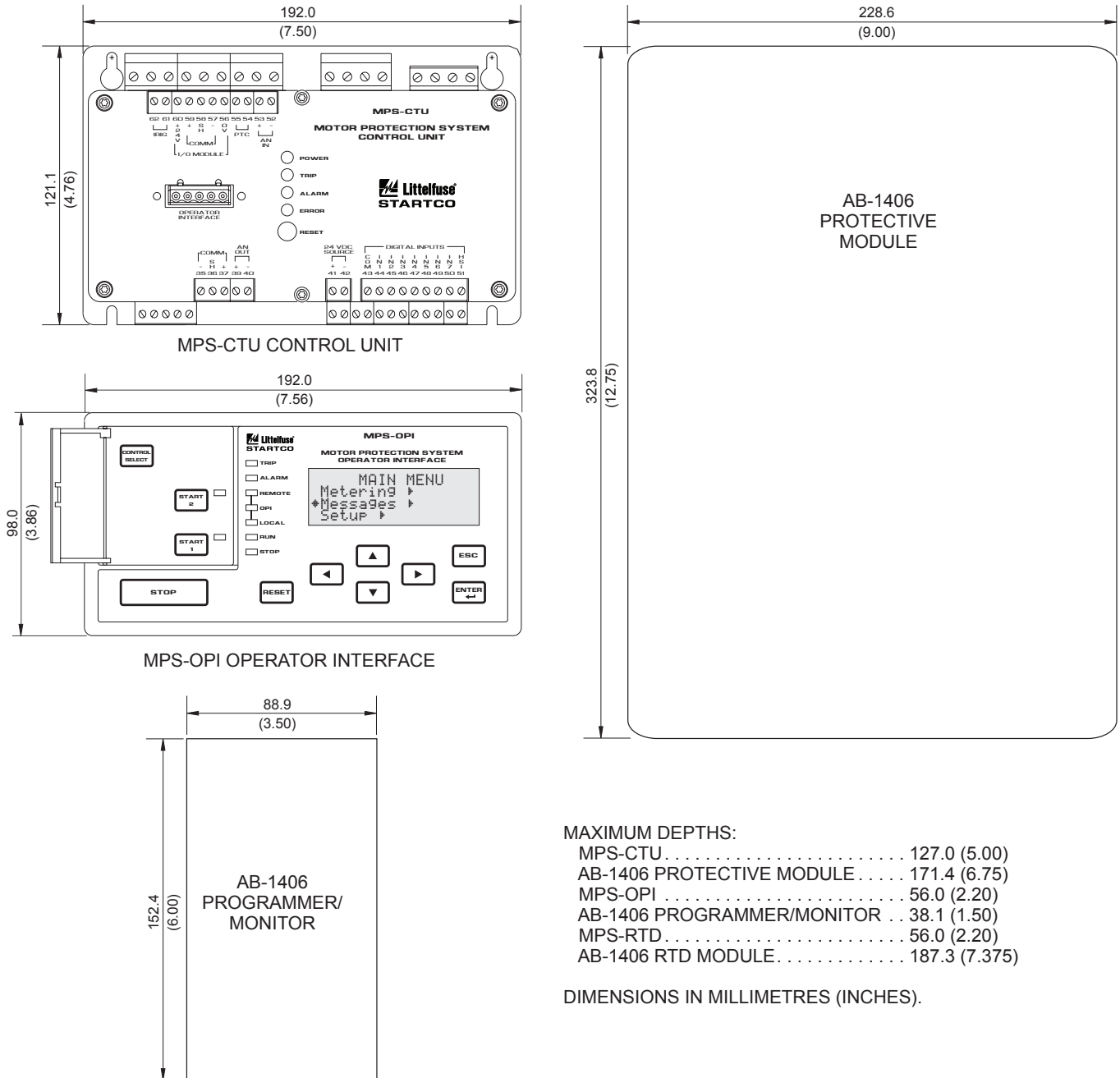

MAXIMUM DEPTHS:

MPS-CTU	127.0 (5.00)
AB-1406 PROTECTIVE MODULE	171.4 (6.75)
MPS-OPI	56.0 (2.20)
AB-1406 PROGRAMMER/MONITOR	38.1 (1.50)
MPS-RTD	56.0 (2.20)
AB-1406 RTD MODULE	187.3 (7.375)

DIMENSIONS IN MILLIMETRES (INCHES).

Figure 1A: Physical Dimensions

AB BULLETIN 1406 TO MPS MOTOR PROTECTION SYSTEM RETROFIT

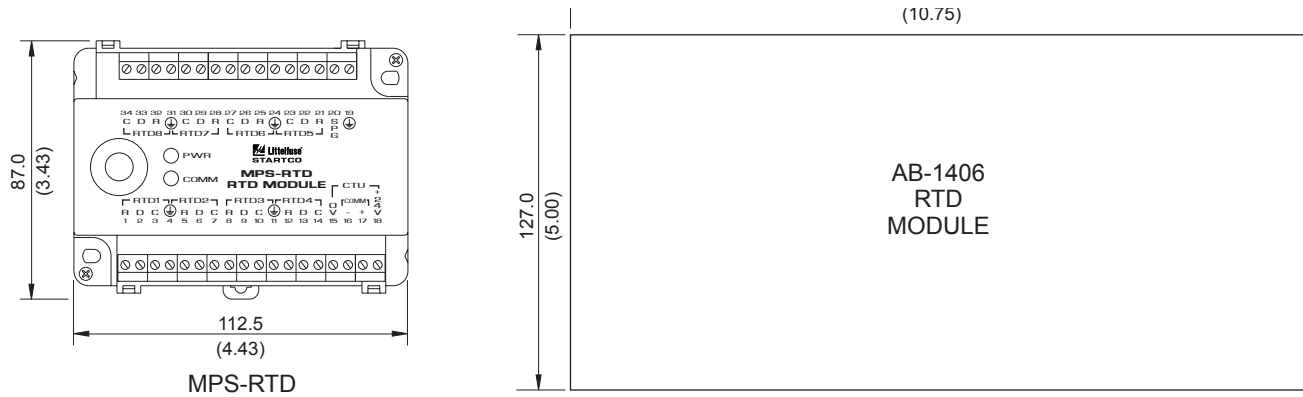

Figure 1B: Physical Dimensions

When the MPS-CTU Control Unit is mounted as shown below, its terminal locations are very similar to the AB-1406. Physical orientation does not affect performance.

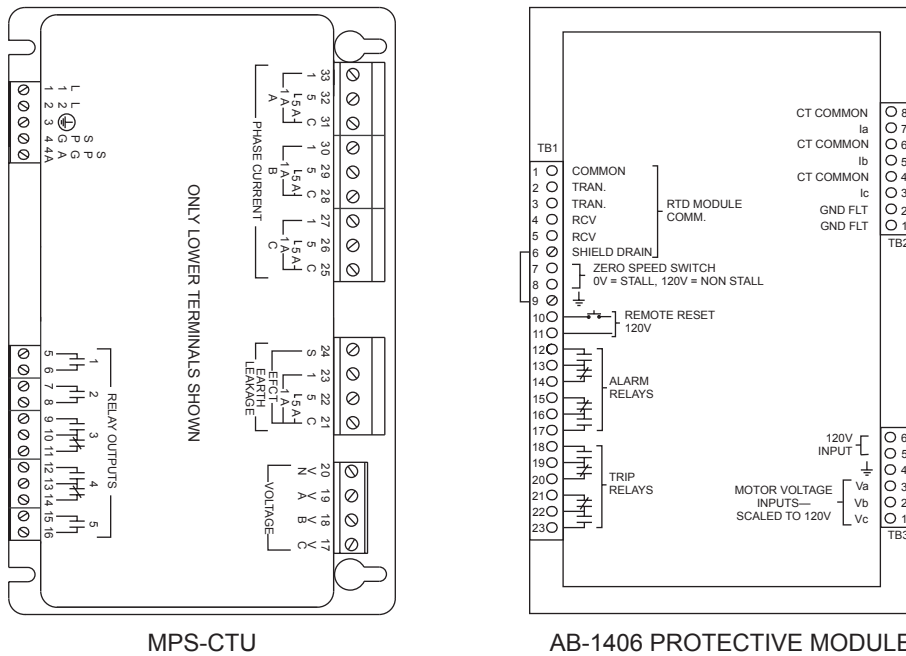

Figure 2: Terminal Layouts (not to scale)

AB BULLETIN 1406 TO MPS MOTOR PROTECTION SYSTEM RETROFIT

Before the AB-1406 is removed from service, the following information should be recorded. Use this table as a guideline when programming the MPS to mimic an AB-1406.

AB-1406 Function #	Description	MPS-OPI Menu Location
1:	Phase CT primary rating (A)	Setup / System Ratings / CT Primary
2:	Full load current FLA (A)	Setup / System Ratings / FLA Rating
3:	Locked rotor current (A)* * MPS is set as (x FLA)	Setup / Protection / Overload / LR Current
4:	Line-to-Line voltage (V)* * AB-1406 uses 2 PT method	Setup / System Ratings / System Voltage Setup / System Ratings / V Connection
5, 6:	NOT REQUIRED	
7:	Locked rotor time, cold (s) Locked rotor time, hot = 0 s	Setup / Protection / Overload / LR Time Cold Setup / Protection / Overload / LR Time Hot
8:	Allowable Acceleration Time(s)* * Zero speed switch input required	Setup / Digital Inputs / Digital Input 2 / In 2 Bypass Delay
9: ¹	Number of starts per time increment	Setup / Protection / Starts/hour / # Starts/hour
10: ¹	Time increment (hours)	Setup / Protection / Starts/hour / Time between
11:	Phase unbalance (%FLA) Phase unbalance delay = 2 s Phase unbalance alarm = 90% Trip Level	Setup / Protection / Unbalance (I) / Trip Level Setup / Protection / Unbalance (I) / Trip Delay Setup / Protection / Unbalance (I) / Alarm Level
12:	Phase reversal protection (enable / disable)	Setup / Protection / Phase Reverse (I)
13:	Undervoltage (% line V)	Setup / Protection / Undervoltage / Trip Level
14:	Undervoltage trip delay (s)	Setup / Protection / Undervoltage / Trip Delay
15:	Ground-fault CT primary rating (A)	Setup / System Ratings / EF-CT Primary
16:	Ground-fault alarm level (A)* Ground-fault alarm delay = 0 s	Setup / Protection / Earth Fault / Alarm Level Setup / Protection / Earth Fault / Alarm Delay
17:	Ground-fault trip level (A)*	Setup / Protection / Earth Fault / Trip Level
18:	Ground-fault trip delay (ms) * MPS is set as (x EFCT primary)	Setup / Protection / Earth Fault / Trip Delay
19:	Low level fault current (x FLA)	Setup / Protection / Overcurrent / Trip Level
20:	Jam (x FLA)	Setup / Protection / Jam / Trip Level
21:	Trip inhibit (enable / disable)* * MPS provides Aux. Overcurrent Setpoint	Setup / Protection / Aux. Overcurrent
22:	Underload (%FLA)	Setup / Protection / Undercurrent / Trip Level
23:	Underload trip delay (s)	Setup / Protection / Undercurrent / Trip Delay
24:	Ultimate Trip Current (x FLA)	Setup / System Ratings / Service Factor
25:	Winding alarm temperature (°C)	Setup / Protection / RTD temperature
26:	Winding trip temperature (°C)	RTD type, function, and trip and alarm setpoints are programmable for each RTD
27:	Bearing alarm temperature (°C)	
28:	Bearing trip temperature (°C)	
29+:	NOT REQUIRED	

TABLE : Setup Information.

¹ The MPS is programmed with a value for the maximum number of starts in one hour, and with a value for the minimum time between consecutive starts. The AB-1406 is programmed with a value for the maximum number of starts in a programmable time interval. These values are similar but not interchangeable.

AB BULLETIN 1406 TO MPS MOTOR PROTECTION SYSTEM RETROFIT

In the MPS-OPI menu location *Setup / Relay Outputs / Relay x*, assign Output Relay 3 the *Alarm1* function, Output Relay 4 the *Trip1* function, and select *Fail-Safe* or *Non-Fail-Safe* operating mode. This allows the MPS output relays to mimic the AB-1406 output relays. There are many additional protective functions provided with the MPS that are not listed in Table 1. The MPS manual, available at www.startco.ca, describes each additional feature in detail.

Install the MPS following the wiring guidelines shown in Fig. 3. These guidelines assume a typical installation of the AB-1406 Motor Protector. If remote reset and zero speed switch inputs are required, connect them to Digital Input 1 and Digital Input 2 on the MPS CTU. Program Digital Input 1 as *Reset* under *Setup / Digital Inputs / Digital Input 1 / Function*. Program Digital Input 2 as *Trip 1 (with delay)* under *Setup / Digital Inputs / Digital Input 2 / Function*. The *Bypass Delay* value is found in Table 1, listed under AB-1406 Function #8.

CAUTION – All guidelines involved in this document assume a typical installation of the AB-1406. All wiring and set points should be confirmed. Be sure to follow all proper safety procedures when accessing the wiring / terminals on these devices.

AB BULLETIN 1406 TO MPS MOTOR PROTECTION SYSTEM RETROFIT

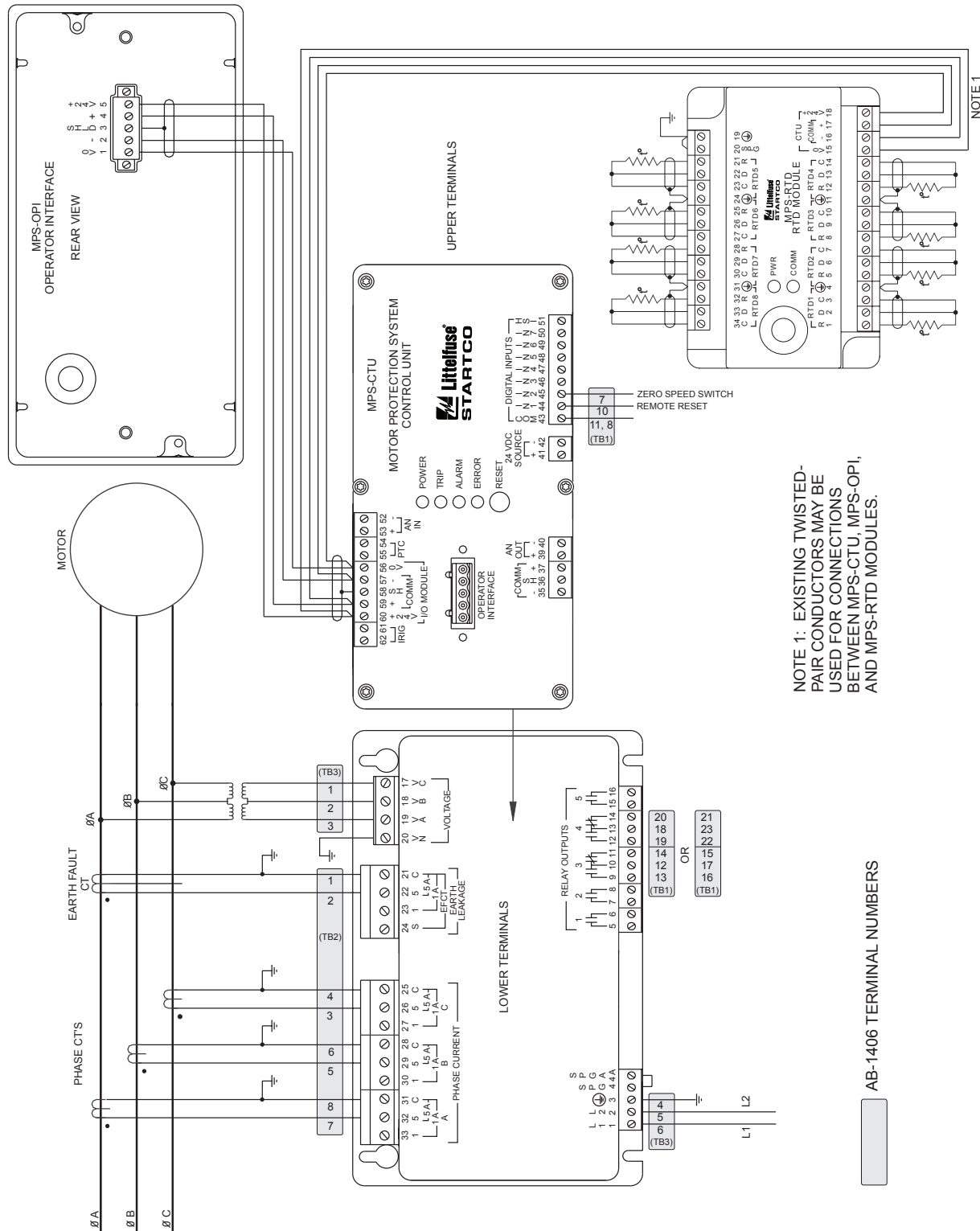

Figure 3: Installation